



GRU DA CITTÀ SENZA CUSPIDE - TOP LESS CITY CRANE  
CITY CRANE SANS POINÇON - GRÚA DE CIUDAD SIN CÚSPIDE  
ГОРОДСКОЙ КРАН БЕЗ ШПИЛЯ

# MRT42



# RAIMONDI

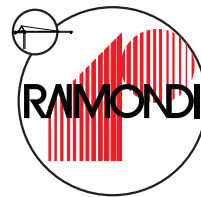

*Scheda Tecnica*  
*Technical Data Sheet*  
*Fiche technique*  
*Ficha técnica*  
*Техническая спецификация*



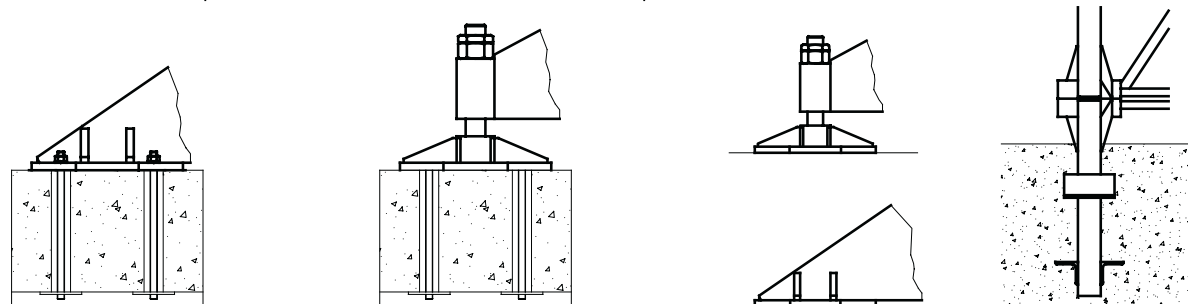
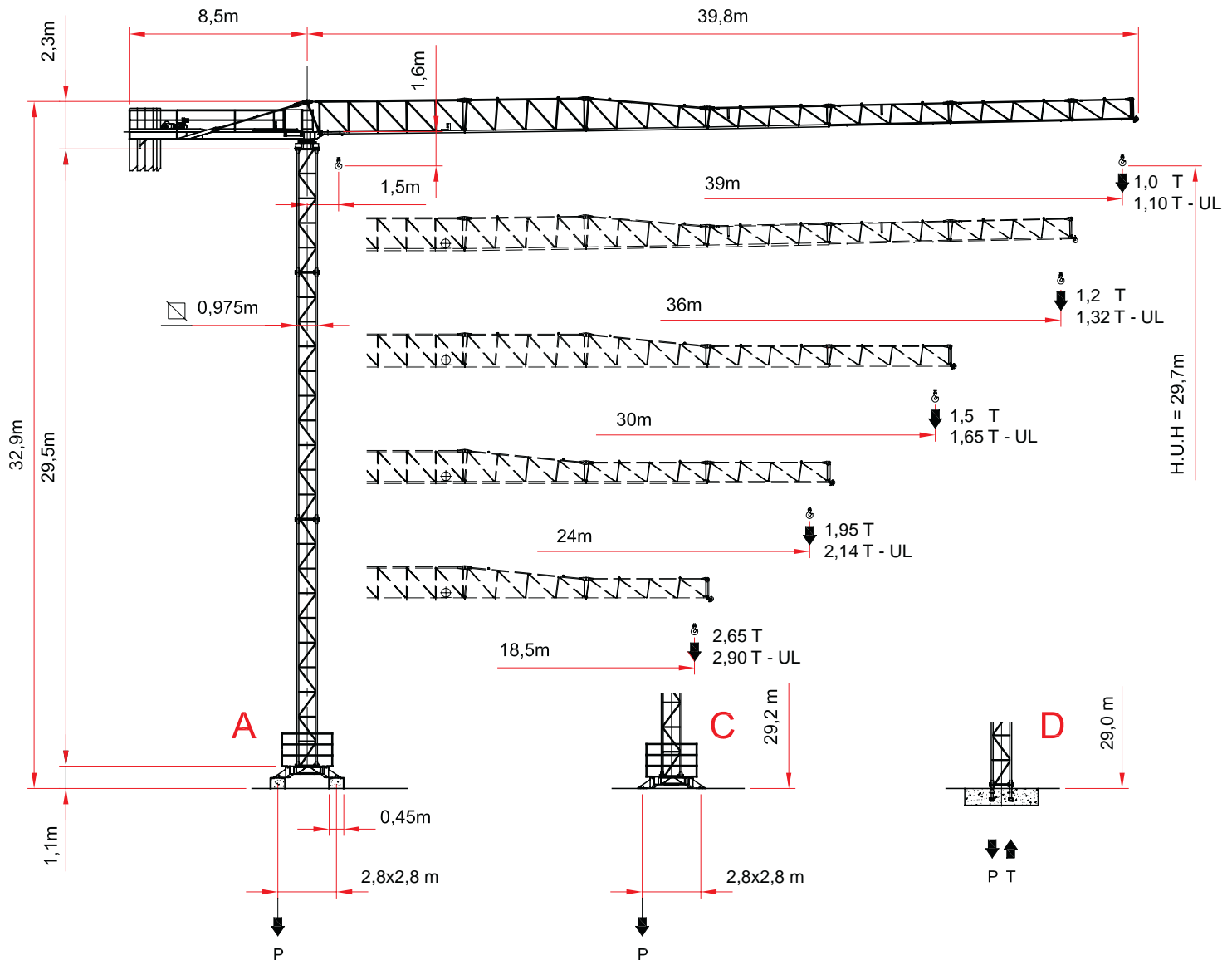

**A**

**A**

**C**

**D**

UL = ULTRALIFT CONTROL

## ALTEZZA SOTTOGANCIO

HEIGHT UNDER HOOK - HAUTEUR SOUS CROCHET - ALTURA BAJO GANCHO - ВЫСОТА ПОД КРЮКОМ

SU BASE - ON CROSSBASE - SUR CHASSIS - SOBRE BASE - НА ОСНОВАНИИ  
**L=2,8 mt.**

H (m)	max. Z (t)	P (KN)	H (m)	max. Z (t)	P (KN)
29,7	32	268	29,2	32	266
23,8	28	235	23,2	28	234
17,9	28	216	17,3	28	211

SU BASE - ON CROSSBASE - SUR CHASSIS - SOBRE BASE - НА ОСНОВАНИИ  
**L=3,2 mt.**

H (m)	max. Z (t)	P (KN)	H (m)	max. Z (t)	P (KN)
29,7	28	234	29,2	28	233
23,4	24	208	23,2	24	207
17,9	24	189	17,3	24	189

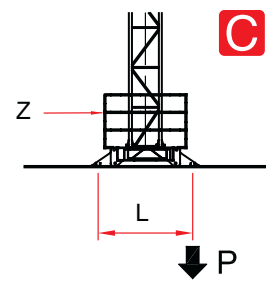
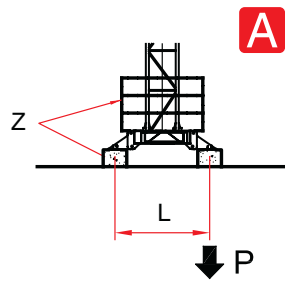

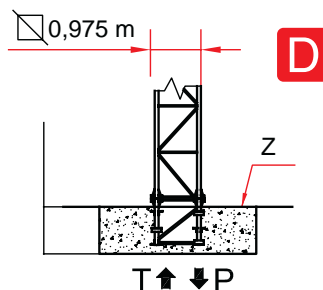

SU PLINTO - STATIONARY - SUR PIEDS DE SCELLEMENT - SOBRE PLINTO - НА ЦОКОЛЕ

H (m)	T (KN)	P (KN)
17,2	278	375
23,1	315	418
29,0	363	470



## PORTATA

LOAD - CHARGE - ALCANCE - ГРУЗОПОДЪЕМНОСТЬ

Portata max - Max s.w.l. Charge maxi - Alcance máx. Макс. грузоподъемность		 2000 kg.					 4000 kg.				
Braccio - Jib Flèche - Pluma Стрела	m.	18	24	30	36	39	18	24	30	36	39
Campo di portata max da Max s.w.l. range from Charge maxi de Rango de capacidad de carga máx. de Макс. Диапазон грузоподъемности от	1,5 m a to à a до	18,0	23,5	23,1	22,7	21,0	12,3	12,1	11,8	11,6	10,6
Raggi (m.) Portée (m.) Radii (m.) Radios (m.) Радиусы (м.)	8	2000	2000	2000	2000	2000	4000	4000	4000	4000	4000
	10	2000	2000	2000	2000	2000	4000	4000	4000	4000	4000
	12	2000	2000	2000	2000	2000	4000	4000	3945	3845	3508
	14	2000	2000	2000	2000	2000	3480	3415	3337	3251	2965
	16	2000	2000	2000	2000	2000	3011	2955	2886	2812	2563
	18	2000	2000	2000	2000	2000	2650	2600	2540	2474	2253
	20		2000	2000	2000	2000		2319	2264	2206	2008
	22		2000	2000	2000	1898		2090	2041	1987	1808
	24		1950	1918	1882	1724		1900	1855	1806	1642
	26			1757	1724	1578			1699	1654	1503
	28			1619	1588	1454			1565	1524	1384
	30			1500	1471	1346			1450	1411	1281
	32				1369	1252				1313	1191
	34				1280	1169				1227	1112
36				1200	1096				1150	1042	
39					1000					950	

Con sistema "ULTRALIFT" tutte le portate intermedie sono aumentate del 10%

All intermediate loads are increased of 10% if the crane is equipped with "ULTRALIFT" control

Les charges intermédiaires sont augmentées de 10% si la grue est équipée avec contrôle "ULTRALIFT"



Con sistema ULTRALIFT todas las capacidades de carga intermedias se aumentan un 10%

При помощи системы ULTRALIFT все промежуточные величины грузоподъемности увеличиваются на 10%

## CARATTERISTICHE AZIONAMENTI PRINCIPALI

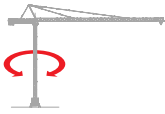
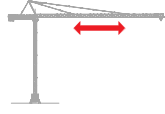
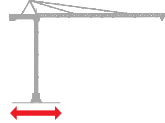
GENERAL TECHNICAL CHARACTERISTICS - CARACTERISTIQUES DES MECHANISMES DE DISTRIBUTION  
 CARACTERÍSTICAS ACCIONAMIENTOS PRINCIPALES - ХАРАКТЕРИСТИКИ ОСНОВНЫХ ПРИВОДОВ

		<b>Velocità - Speed Vitesse - Velocidad Скорость</b>	<b>Potenza - Power Puissance - Potencia Мощность</b>
Rotazione - Slewing Orientation - Rotación Вращение		0,3 / 0,6 / 1,0 min <sup>-1</sup>	3,0 Kw
Carrello - Trolley Chariot - Carro Тележка		16 / 31,7 / 47,8 m/min Progressivo - Progressive	2,2 Kw
Traslazione - Rail Translation - Traslación Горизонтальное перемещение		13 m/min	2 x 2,9 Kw

Tipo Type Type Тип		Potenza - Power Puissance - Potencia Мощность		Fune - Rope Cable - Cable Трос	Marcia Step Vitesse Marcha Передача				
		CV - ch Ps - hp	kW			m.	Carico - Load Charge - Carga Грузоподъемность	Velocità - Speed Vitesse - Velocidad Скорость	Carico - Load Charge - Carga Грузоподъемность
10 HP - 2,0 VF		10	7,3	130	1	2000	4,3		
					2	2000	17,5		
					3	1000	35		
						0 - 100 (*)	44 (*)		
15 HP - 4,0 VF		15	11	144	1	2000	6,25	4000	3,1
					2	2000	25	4000	12,5
					3	1000	50	2000	25
						0 - 200 (*)	60 (*)	0 - 400 (*)	30 (*)











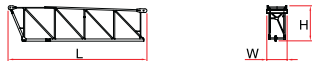

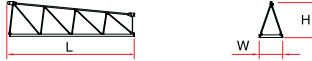
(\*) Velocità regolata automaticamente tramite sensore di corrente

Conforme alla direttiva 2000/14/CE sul livello acustico - In compliance with the 2000/14/CE instruction on noise level - Conforme directive 2000/14/CE sur le niveau acoustique  
 Conforme con la directive 2000/14/CE sobre el nivel acustico - Соответствует директивам 2000/14/CE, что касается уровня шума

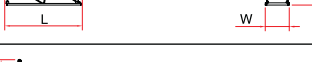
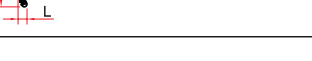
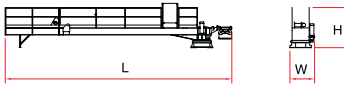
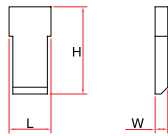
Forza motrice totale Total installed power Puissance totale des moteurs Fuerza motriz total Общая движущая сила	7,3 Kw (10HP)	11 Kw (15HP)
	19 Kw	22 Kw

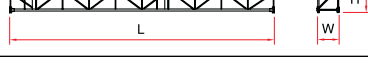
## PESI E INGOMBRI



PACKING LIST - LISTE DE COLISAGE - PESOS Y DIMENSIONES - ВЕС И ГАБАРИТНЫЕ РАЗМЕРЫ

Pos. Item	Pezzi Pieces	Denominazione Description	Schizzo Sketch	Dimensioni Dimensions			Peso Weight		
				L	W	H	Unit	Total	
1	1	<b>Elemento di freccia</b> Jib element Elément deèche Elemento de flecha Элемент стрелы	n° 1 	7,712	0,900	1,630	672	-	
	1		n° 2 	5,987	0,900	1,630	410	-	
	1		n° 3 	5,988	0,900	1,630	371	-	
	1		n° 4 	5,978	0,900	1,080	355	-	
	1		n° 5 	5,970	0,900	1,030	240	-	
	1		n° 6 	5,970	0,900	1,030	227	-	
	1		n° 7 	3,010	0,900	1,030	145	-	
	1		n° 8 	0,400	0,900	1,242	33	-	
2	1	<b>Controfreccia girevole, argano di sollev., quadro elettrico, carrello freccia etc.</b> Counterjib-tournable, hoisting winch, trolley jib, electrical box etc. Contreèche tournante, treuil de levage, chariot de fleche, armoire électrique etc. Contraflecha giratoria, cabrestante de elevación, cuadro eléctrico, carro flecha, etc. Поворот. контрстрела, подъем. лебедка, электрощит, тележка стрелы и т. д.		10,050	1,640	2,13	3600	-	
3	2	<b>Blocchi di contrappeso</b> Counterweight block Contre-poids Bloques de contrapeso Блоки противовеса		A36+3	0,840	0,375	3,000	1607	3214
	B36+3			0,840	0,180	3,000	787	2361	
	C39+3			0,840	0,470	3,000	2000	-	
4	1	<b>Elemento di torre</b> Tower element Elément de mature Elemento de torre Башенный элемент		2,360	0,975	1,135	382	-	
	1			5,900	0,975	1,135	795	-	
	1			11,800	0,975	1,135	1595	-	
5	1	<b>Tronchetto di fondazione</b> Expendable foundation element Elément a sceller Tronco de fundación Ствол основания		1,180	0,975	1,135	400	-	
6	1	<b>Crociera di base</b> Cross-base Chassis de base Cruceta de base Крестовина основания		3,200	3,200	0,600	1450	-	
7	4	<b>Blocco di appoggio</b> Concrete pad Sabot en béton Bloque de apoyo Опорный блок		2,400	0,600	0,450	1522	6088	

## PESI E INGOMBRI

PACKING LIST - LISTE DE COLISAGE - PESOS Y DIMENSIONES -

ВЕС И ГАБАРИТНЫЕ РАЗМЕРЫ

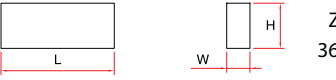
8	1	Bilancino di traslazione folle Driving bogie Boggie fou Balancín de traslación loco Не приводной балансир для горизонтального перемещения		0,800	0,195	0,385	190	-
9	1	Bilancino di traslazione motorizzato Driven bogie Boggie motorisée Balancín de traslación motorizado Приводной балансир для горизонтального перемещения		0,925	0,425	0,385	310	--
10	1	Blocco di zavorra Base ballast block Lest de base Bloque de lastre Блок балласта		2,400	0,520	0,700	2000	--

## Piano di carico

Track load plan

A	<p><b>Elementi braccio N°1-2-3-8, N°2 elementi torre 11,8m - 12 bl. zavorra</b>                      Jib elements N°1-2-3-8, N°2 tower elements 11,8m length, N°12 ballast blocks                      N°12 blocs lest de base, N°2 élément de mature 11,8m , element de fleché N°1-2-3-8                      Elementos pluma N°1-2-3-8, N°2 elementos torre 11,8m – 12 bloques Lastre                      Элементы стрелы N°1-2-3-8, N°2 элементы башни 11,8 м – 12 блоков балласта</p>
B	<p>Blocchi di contrappeso, contrefreccia, base completa, elementi freccia N 4-5-6, N ° 2 blocchi di zavorra.                      Counterweight blocks, counterjib, complete base, jib elements N 4-5-6, N ° 2 ballast blocks.                      Blocs de contrepoids, contrefleche, chassis de base, élément de fleché N°4-5-6, N°2 blocs lest de base.                      Bloques de contrapeso, contraflecha, base completa, elementos flecha N° 4-5-6, N°2 bloques de lastre                      Блоки противовеса, контрстрела, полное основание, элементы стрелы N° 4-5-6, N°2 блока балласта</p>

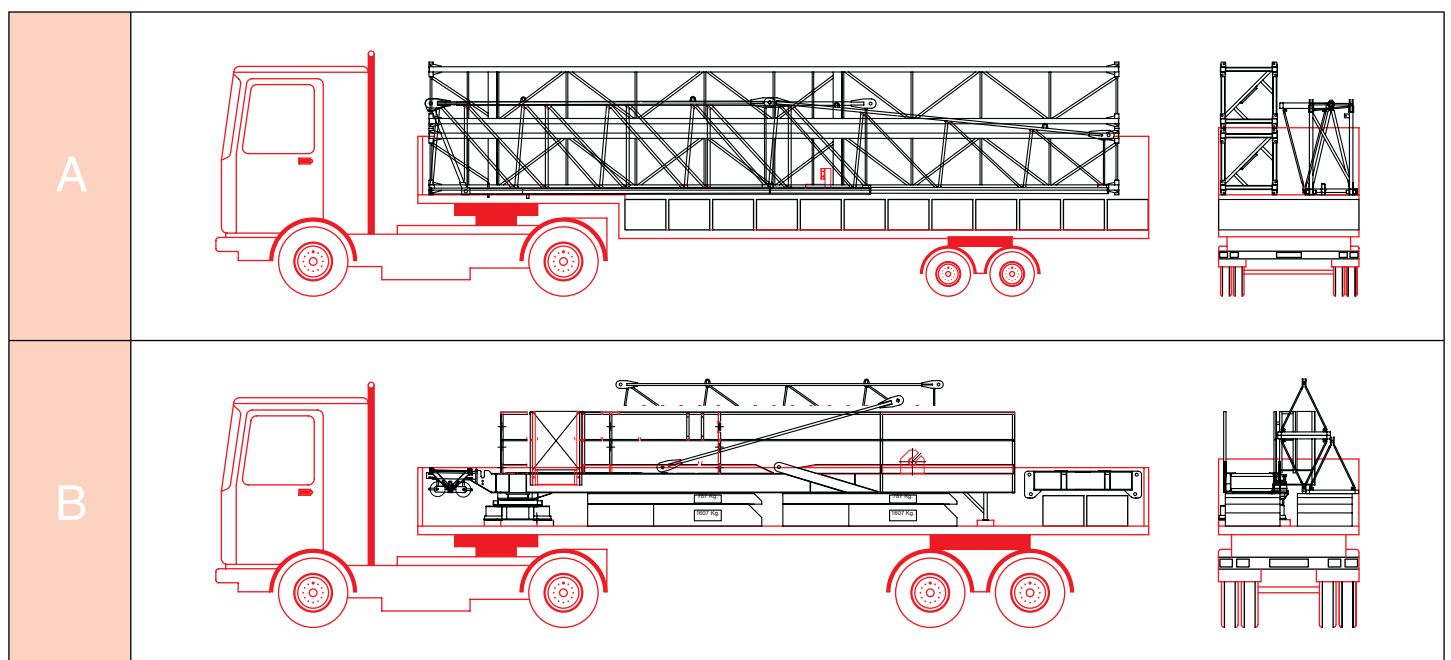



**CARLO RAIMONDI** fu Rodolfo S.p.A.  
C.so Garibaldi, 253 - 20025 Legnano (MI) Italy  
Telefono 0039.0331.548061 - Fax 0039.0331.450400  
[www.raimondigru.it](http://www.raimondigru.it)